



# Service Manual

## Proportioning Unit

### evolution G-125 A / G-200 A



Issue 4.2 20/03/23  
Ref. NR-00011-ENG



***Before installing the unit and starting it up, carefully read all the technical and safety documentation included in this manual. Pay special attention to the information to know and understand the operation and the conditions of use of the unit. All of the information is aimed at enhancing User Safety and avoiding possible breakdowns derived from the incorrect use of the unit.***



## WARRANTY

HI-TECH SPRAY EQUIPMENT, S. A. (hereinafter "HI-TECH") grants this Limited Guarantee to the original buyer (hereinafter the "Client") for the unit and the original accessories given with the unit (hereinafter the "Product") against any fault in the design, materials or manufacture of the Product at the time of the first purchase by the user and for a duration of two (2) years thereafter.

If during the guarantee period and under normal conditions of use, the Product should fail to work correctly due to defects of design, material or manufacture, the authorised distributor of the country where the HI-TECH Product or technical assistance service has been purchased shall repair or replace the Product in accordance with what is established in the following:

### CONDITIONS

- a) The validity of this guarantee will be subject to the presentation of the original invoice issued by the HI-TECH authorised distributor for the sale of the Product along with the Product handed over for repair or replacement, which must show the date of purchase and the serial number. HI-TECH reserves the right to refuse to give the guarantee service when the indicated data fail to appear on the invoice or have been modified after the purchase of the Product.
- b) The repaired or replaced Product will continue to maintain the original guarantee for the time remaining until the end of the guarantee or for three (3) months from the repair date, if the remaining period of the original guarantee were shorter.
- c) This guarantee will not be applied to the faults in the Product caused by its faulty installation, the natural wear and tear of the components, any use other than that considered normal for this Product or which should fail to strictly comply with the instructions of use provided by HI-TECH; due to accident, carelessness, adjustments, alterations or modifications of the Product not authorised by HI-TECH or due to the use of accessories, heating devices, pumping equipment and/or dispensers that have not been approved or manufactured by HI-TECH.
- d) The guarantee applicable to the components and accessories forming part of the Product and which have not been made by HI-TECH will be limited to the guarantee offered by the original manufacturer thereof.

**HI-TECH WILL NOT RECOGNISE ANY EXPRESS ORAL OR WRITTEN GUARANTEES OTHER THAN THIS PRINTED LIMITED GUARANTEE. ALL IMPLICIT GUARANTEES, INCLUDING, WITHOUT LIMIT, ADAPTATION FOR A SPECIFIC USE, ARE SUBJECT TO THE DURATION OF THIS WRITTEN GUARANTEE. HI-TECH DOES NOT ASSUME ANY KIND OF COMMITMENT OR RESPONSIBILITY FOR ALL POSSIBLE DAMAGE OR EXPENSE CAUSED BY FAULTS IN THE OUTPUT OF THE PRODUCT, ITS WORKING OR THE DISPENSING OF MATERIAL THROUGH THE PRODUCT, INCLUDING, WITHOUT LIMITATION, ALL EXPENSES CAUSED BY DAMAGE TO PEOPLE OR PROPERTY. EQUALLY, HI-TECH WILL IN NO CASE ACCEPT LIABILITY FOR THE LOSS OF SPECULATIVE PROFITS OR COMMERCIAL LOSSES. ALL REPAIRS OR REPLACEMENT OF FAULTY PRODUCTS WILL CONSTITUTE THE COMPREHENSIVE FULFILMENT OF HI-TECH'S OBLIGATIONS WITH RESPECT TO THE CLIENT. HI-TECH DOES NOT IN ANY WAY GUARANTEE THE SUITABILITY OR APTITUDE OF ITS PRODUCT FOR ANY PARTICULAR PURPOSE OR APPLICATION.**

All information provided on components which have not been manufactured by HI-TECH and which is based on reports received from the original manufacturer, though considered precise and reliable, is provided without any guarantee or responsibility of any explicit or implicit kind.

All concession, sale or financial leasing of the Product by HI-TECH in no case explicitly or implicitly constitutes any authorisation, acceptance or concession for the use of any rights or patents, nor does it encourage, nurture or back their infringement.

The restrictions on the guarantee suppose no limitation on the legal rights of the consumer established in applicable national legislation, nor do they affect any rights derived from the bargain and sale agreement between the consumer and supplier.



## Service Manual

All information provided in this manual has been included in the confidence that it is true, although it does not constitute any responsibility or implicit or explicit guarantee. HI-TECH reserves the right at any time and without prior warning to make all improvements and modifications necessary to this manual, in order to rectify any possible typographical errors, increase the information contained or insert the changes caused to the characteristics and performance of the unit.

## SAFETY AND HANDLING

The equipment described in this manual has been designed and manufactured in compliance with the following European Directives, following as application guide the harmonized standards detailed and in conformity with the relevant UK Statutory Instruments (and their amendments):



### **Directive 2006/42/EC on machinery (UK Supply of Machinery (Safety) Regulations 2008)**

UNE EN 12100:2012 (BS EN ISO 12100:2010)

### **Directive 2014/30/EU on electromagnetic compatibility (UK Electromagnetic Compatibility Regulations 2016)**

UNE EN 55011 (BS UNE EN 55011)

UNE EN 55016-2-1 (BS UNE EN 55016-2-1); UNE EN 55016-2-3 (BS UNE EN 55016-2-3);  
UNE EN 55032 (BS UNE EN 55032)

UNE EN 61000-3-2 (BS UNE EN 61000-3-2); UNE EN 61000-3-3 (BS UNE EN 61000-3-3);  
UNE EN 61000-4-2 (BS UNE EN 61000-4-2); UNE EN 61000-4-3 (BS UNE EN 61000-4-3);  
UNE EN 61000-4-4 (BS UNE EN 61000-4-4); UNE EN 61000-4-5 (BS UNE EN 61000-4-5);  
UNE EN 6100-4-6 (BS UNE EN 6100-4-6); UNE EN 61000-4-8 (BS UNE EN 61000-4-8); UNE  
EN 61000-4-11 (BS UNE EN 61000-4-11)

### **Directive 2014/68/EU on pressure equipment (UK Pressure Equipment (Safety) Regulations 2016)**

UNE EN 809:1999 +A1 (BS EN 809:1998 +A1:2009)

### **Directive 2014/35/EU on electrical safety (UK Electrical Equipment (Safety) Regulations 2016)**

UNE EN 60204-1:2019 (BS EN 60204-1:2018)

### **Directive 2003/10/EC on noise level (UK The Control of Noise at Work Regulations 2005)**

UNE EN ISO 3740 (BS EN ISO 3740:2019)

UNE EN ISO 3746 (BS EN ISO 3746:2010)

### **Directive 2011/65/EU on the restriction of the use of certain hazardous substances in electrical and electronic equipment with amendment 2015/863/EU (UK The Restriction of the Use of Certain Hazardous Substances in Electrical and Electronic Equipment Regulations 2012)**

### **Directive 2012/19/EU on waste electrical and electronic equipment (UK The Waste Electrical and Electronic Equipment Regulations 2013)**

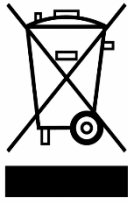

Electrical products cannot be thrown out with the rubbish. They must be taken to a dedicated collection point for an environmentally sound disposal in accordance with local regulations. You must contact your local collective or retailer for information about recycling. Before leaving WEEE at appropriate collection facilities, batteries must be removed and disposed of separately for proper recycling. The packaging materials are recyclable. Dispose of packaging materials in an environmentally sound manner and place them at the disposal of recycling sectors.

### TRANSPORT AND STORAGE

Proper precautions must be taken so that the equipment can withstand the effects of transport and storage temperatures between -25°C and +55°C or up to +70°C for short periods that do not exceed 24 hours. Also, appropriate means to prevent damage from moisture, vibrations or shocks must be foreseen.

This chapter contains information on the safety, handling and use of the **evolution G-125 A / evolution G-200 A** series proportioning unit.



**Before installing the unit and starting it up, carefully read all the technical and safety documentation included in this manual. Pay special attention to the information to know and understand the operation and the conditions of use of the unit. All of the information is aimed at enhancing User Safety and avoiding possible breakdowns derived from the incorrect use of the unit.**

**WARNING!** establishes information to alert on a situation that might cause serious injuries if the instructions are not followed.

**PRECAUTION!** establishes information that indicates how to avoid damage to the unit or how to avoid a situation that could cause minor injuries.

**NOTE:** is relevant information on a procedure being carried out.

Careful study of this manual will enable the operator to know the characteristics of the unit and the operating procedures. By following the instructions and recommendations contained herein, you will reduce the potential risk of accidents in the installation, use or maintenance of the unit; you will provide a better opportunity for incident-free operation for a longer time, greater output and the possibility of detecting and resolving problems fast and simply.

Keep this Service Manual for future consultation of useful information at all times. If you lose this manual, ask for a new copy from your **HI-TECH** local distributor or directly contact **HI-TECH SPRAY EQUIPMENT, S.A.**

**WARNING!** The design of the evolution G-125 A / G-200 A series proportioning unit does not allow its use in potentially explosive atmospheres or to exceed the pressure and temperature limits described in the technical specifications of this manual.



**Service Manual**

When working with the unit, it is recommended that the operator wear suitable clothing and elements of personal protection, including, without limitation, gloves, protective goggles, safety footwear and face masks. Use breathing equipment when working with the machine in enclosed spaces or in areas with insufficient ventilation. The introduction and follow-up of safety measures must not be limited to those described in this manual. Before starting up the machine, a comprehensive analysis must be made of the risks derived from the products to be dispensed, the type of application and the working environment.



***To prevent all possible bodily harm caused by incorrect handling of the raw materials and solvents used in the process, carefully read the safety information provided by your supplier.***

***Deal with the waste caused according to current regulations.***



***Disconnect the unit from the power supply before carrying out any operation inside the electrical console.***

***The electrical maintenance of the machine must only be performed by a qualified electrician.***



***To avoid damage caused by the impact of pressurized fluids, do not open any connection or perform maintenance work on components subject to pressure until the pressure has been completely eliminated.***

***Use suitable protection when operating, maintaining or remaining in the operating area of the unit. This includes, but is not limited to, the use of masks, protective goggles, gloves, shoes and safety clothing.***



***The unit includes components that reach temperatures that are liable to cause burns. The hot parts of the unit must not be handled until they have cooled.***



***To prevent serious harm by crushing or loss of limbs, do not work with the unit without the safety guards installed on all moving parts. Make sure that all of the safety protections are correctly reinstalled after all repair or maintenance work is completed.***

## CHARACTERISTICS

The **evolution G-125 A / G-200 A** proportioning unit has been designed and built for the application of Polyureas, chemical systems for polyurethane foaming and some two-component epoxy systems. Check with your chemical supplier for the recommended temperatures and pressures.

### Principal Heating System

Consists of two independent heaters without seals. Each heater has four 1250 W (1500 W G-200 A) heating elements, that give the unit a total power of 5000 W (6000 W G-200 A), and the necessary control and safety components for precise operation of the system. Its singular configuration allows a temperature differential ( $\Delta T$ ) of 90° F and application temperatures of up to 194° F under normal conditions of ambient temperature.

### Proportioning System

Comprises two positive displacement piston pumps, driven by a pneumatic motor. The system includes two pressure regulators that allow the working pressures to be equalized in the two directions of pump movement, compensating for the imbalance of pressure caused by the design of the design of the air motor and the effect of the additional pressure of the transfer pumps.

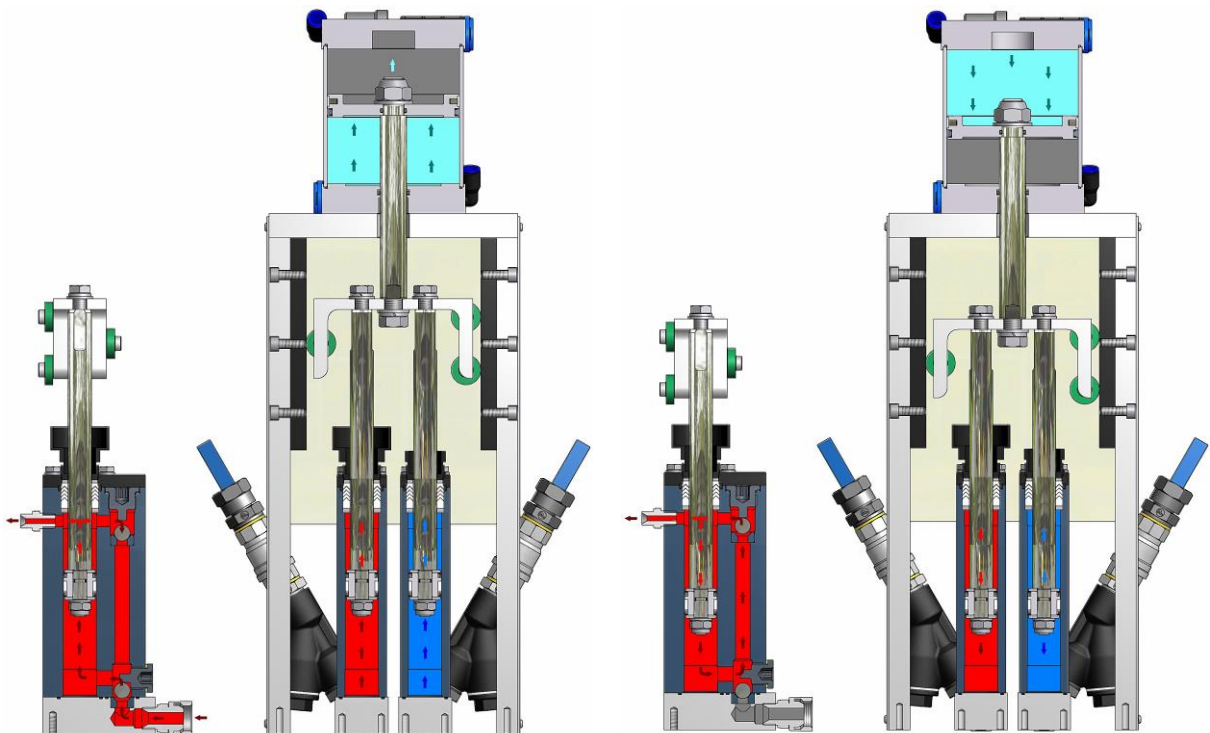



## Service Manual

### Hose Heating System

Designed with a 3000 W isolation transformer that enables effective heating up to a total hose length of 305 ft for foam and 256 ft for polyurea. The system includes an innovative hose heating concept in which the copper heating element is spread evenly around the circumference of the hose, providing a uniform heating watt density and precise control of the product application temperature. This hose heating element design is extremely resistant to fatigue failure.

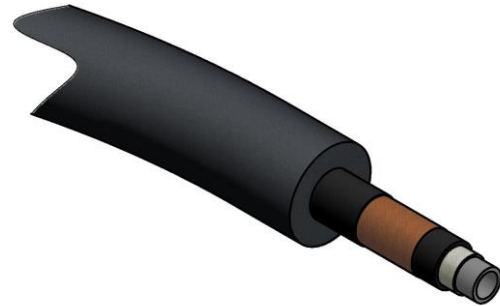

100% circumferential coverage produces the most homogenous distribution of heat available



## TECHNICAL SPECIFICATIONS evolution G-125 A

### Electrical

Main voltage: \_\_\_\_\_ 230/400 V  
 Frequency: \_\_\_\_\_ 50/60 Hz  
 Electrical consumption: \_\_\_\_\_ 22 A @ 3NPE~400 V  
 Electrical consumption: \_\_\_\_\_ 43,5 A @ 3PE~230 V  
 Electrical consumption: \_\_\_\_\_ 58 A @ 1NPE~400 V  
 Heater power: \_\_\_\_\_ (2 X 5 Kw) 10 Kw  
 Hose Transformer Power: \_\_\_\_\_ 3 kW  
 Total Active Power: \_\_\_\_\_ 13 Kw



**Inside the console, there is a terminal strip for connecting the main power (wire not supplied) to the unit. The electrical connection of the unit must only be carried out by a qualified electrician.**

### Mechanical

Maximum working pressure (air supply 8 bar): \_\_\_\_\_ 125 bar (12.5 MPa)  
 Maximum production ratio 1:1: \_\_\_\_\_ 9 Kg/min  
 Minimum production: \_\_\_\_\_ 1 kg/min  
 Maximum hose length: \_\_\_\_\_ 93 m  
 Air consumption @ 6 bar: \_\_\_\_\_ 750 liters/min  
 Recommended compressor: \_\_\_\_\_ 7.5 HP three-phase  
 Approximate weight: \_\_\_\_\_ 120 Kg  
 Dimensions: \_\_\_\_\_ H: 1055 mm / W: 540 mm / L: 550 mm

### Acoustic

A-weighted sound pressure level: \_\_\_\_\_ 74,2 dB (A)  
 A-weighted sound power level: \_\_\_\_\_ 88,6 dB (A)

**Values obtained according to UNE-EN ISO 3746:1995 standard.**

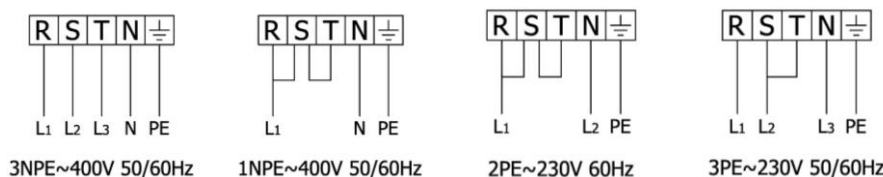

**(\*) For temperatures above 75°C, the maximum hose length will be 78m.**





## TECHNICAL SPECIFICATIONS evolution G-200 A

### Electrical

Main voltage: \_\_\_\_\_ 230/400 V  
 Frequency: \_\_\_\_\_ 50/60 Hz  
 Electrical consumption: \_\_\_\_\_ 26 A @ 3NPE~400 V  
 Electrical consumption: \_\_\_\_\_ 52 A @ 3PE~230 V  
 Electrical consumption: \_\_\_\_\_ 67 A @ 1NPE~400 V  
 Heater power: \_\_\_\_\_ (2 X 6 Kw) 12 kW  
 Hose Transformer Power: \_\_\_\_\_ 3 kW  
 Total Active Power: \_\_\_\_\_ 15 kW



**Inside the console, there is a terminal strip for connecting the main power (wire not supplied) to the unit. The electrical connection of the unit must only be carried out by a qualified electrician.**

### Mechanical

Maximum working pressure (air supply 8 bar): \_\_\_\_\_ 200 bar (20 MPa)  
 Maximum production ratio 1:1: \_\_\_\_\_ 4 Kg/min  
 Minimum production: \_\_\_\_\_ 1 kg/min  
 Maximum hose length (for foam) : \_\_\_\_\_ 93 m  
 Maximum hose length (for polyurea) : \_\_\_\_\_ 78 m  
 Air consumption @ 6 bar: \_\_\_\_\_ 705 liters/min  
 Recommended compressor: \_\_\_\_\_ 7,5 HP three-phase  
 Approximate weight: \_\_\_\_\_ 125 Kg  
 Dimensions: \_\_\_\_\_ H: 1055 mm/ W: 540 mm/ L: 550 mm

### Acoustic

A-weighted sound pressure level: \_\_\_\_\_ 74,2 dB (A)  
 A-weighted sound power level: \_\_\_\_\_ 88,6 dB (A)

**Values obtained according to UNE-EN ISO 3746:1995 standard.**

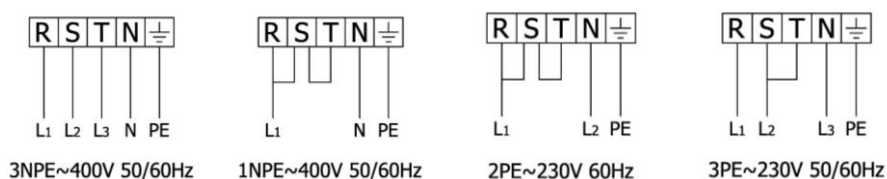

**(\*) For temperatures above 75°C, the maximum hose length will be 78m.**

## GENERAL DESCRIPTION

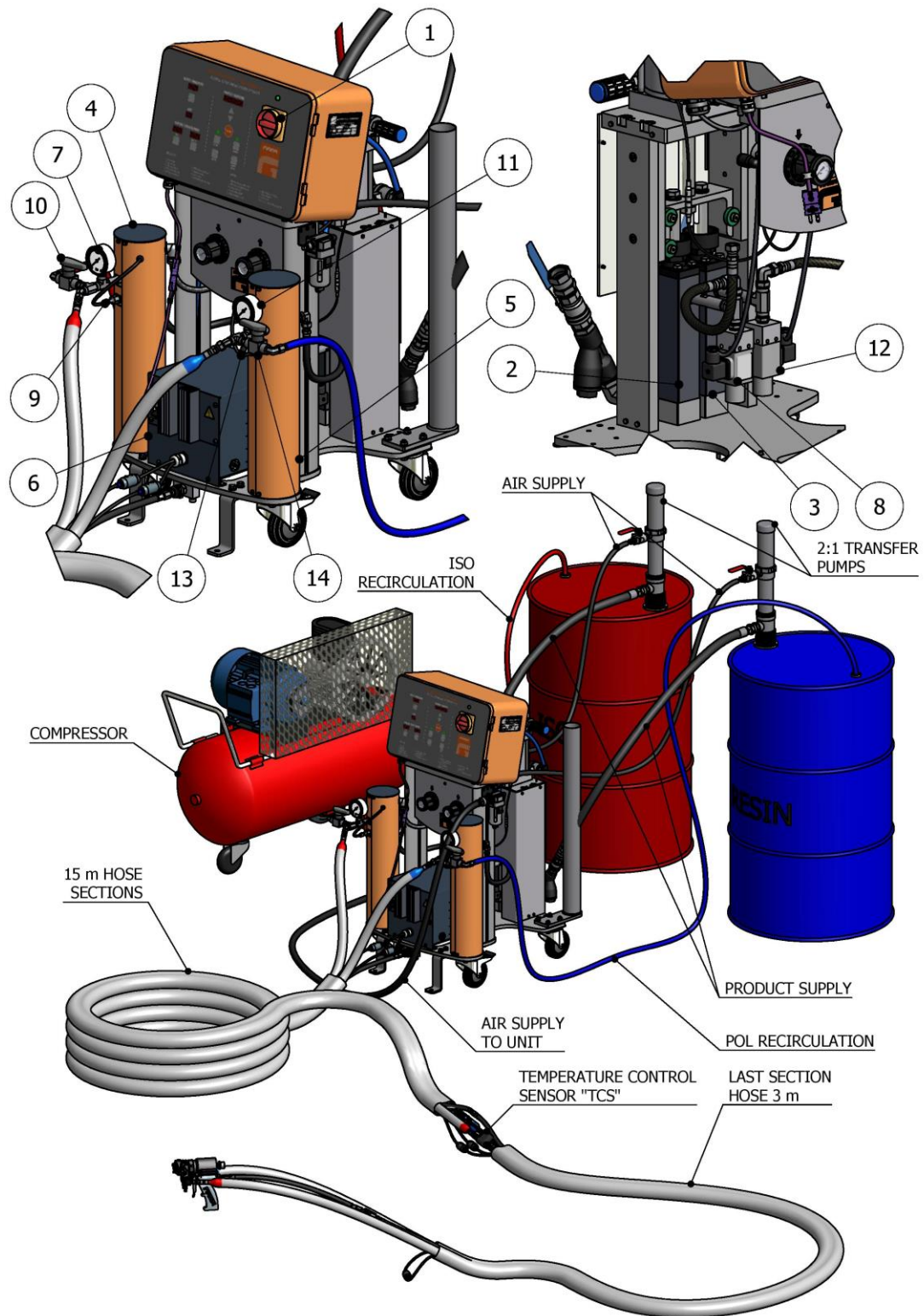

Figure 1. General Description



## Service Manual

### 1. Control Panel

Controls and regulates the correct operation of the unit.

### 2. Isocyanate Proportioning Pump

Meters the Isocyanate.

### 3. Polyol Proportioning Pump

Meters the Polyol.

### 4. Isocyanate Heater

Heats the Isocyanate to the pre-set temperature.

### 5. Polyol Heater

Heats the Polyol to the pre-set temperature.

### 6. Hose Heating Transformer

Supplies the required voltage for heating the hoses.

### 7. Isocyanate Pressure Gage

Indicates the pressure in the Isocyanate circuit.

### 8. Isocyanate Safety Pressure Gauge

Deactivates the directional valve in the event of excessive pressure in the Isocyanate circuit.

### 9. Isocyanate Heater Probe

Provides information on the temperature of the Isocyanate.

### 10. A-Recirculation Valve

### 11. Polyol Pressure Manometer

Indicates the pressure in the Polyol circuit.

### 12. Safety Pressure Gauge of the Polyol Circuit

Deactivates the directional valve in the event of excessive pressure in the Polyol circuit.

### 13. Polyol Heater Probe

Provides information on the temperature of the Polyol.

### 14. R-Recirculation Valve

### 15. Pneumatic Pressure Regulators

The unit has two pressure regulators that allow independent adjustment of the air pressure for the advance cycle and the return cycle of the pneumatic cylinder.

### 16. DIP Selectors TCS Probes

This allows the hose heating control mode to be selected, depending on whether they include a TCS probe for direct temperature control or not. To make a correct selection of the control mode, consult page 10, point 2, of this manual. **Please be aware that after manipulating the DIP selector you should switch off the unit so the change. (in detected buy the board).**



### 17. DIP Selector Control Units

This allows the temperature units to be selected that will be shown on the displays of the control panel. Set to EU for the temperature to be shown in degrees Celsius (°C) or to USA for the temperature to be shown in degrees Fahrenheit **Please be aware that after manipulating the DIP selector you should switch off the unit so the change. (in detected buy the board)**



### 18. DIP Motor Selector

This allows the operation of the hydraulic system to be activated or deactivated. The adjustment is carried out in factory depending on the machine model. **The function of the "DIP Motor" selector is only active in the units with hydraulic actuation. Please be aware that after manipulating the DIP selector you should switch off the unit so the change. (in detected buy the board)**



## CONTROL PANEL

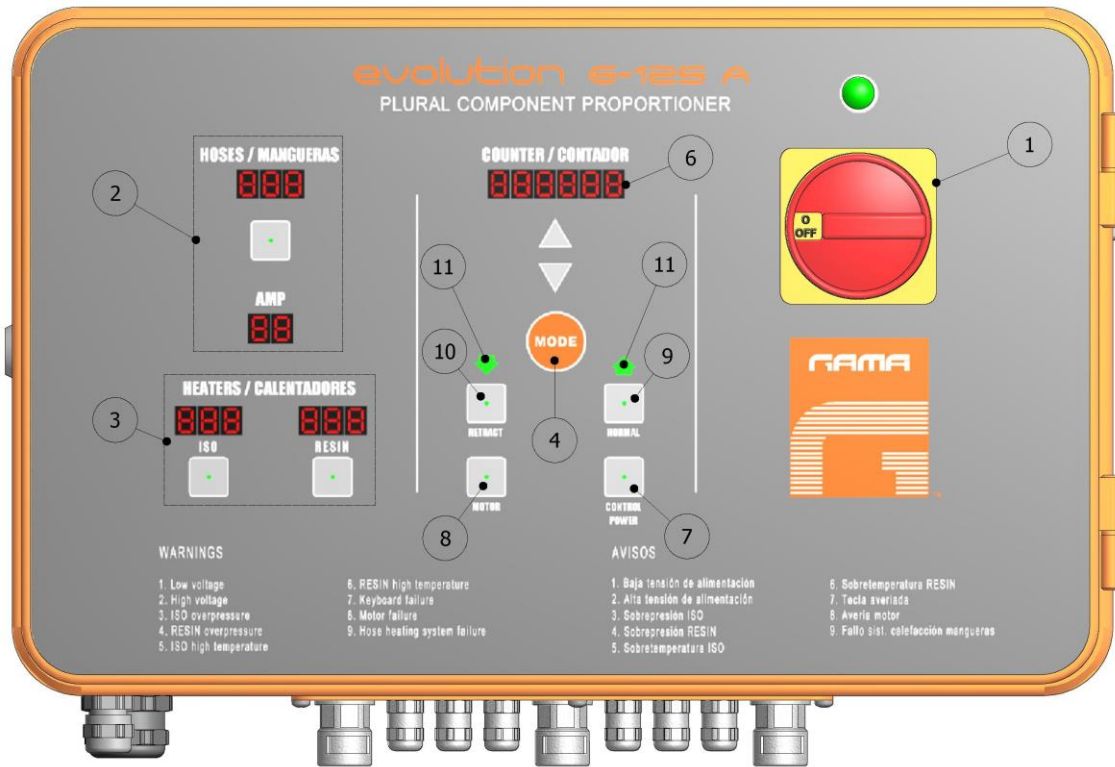

**Figure 2. Control Panel**

The Control Panel allows the optimum working conditions to be selected and set, depending on the characteristics and requirements of the products to be dispensed. Using the MODE key, the different control parameters may be entered. The parameter display will flash for a few seconds to allow the change of this value by pressing the UP / DOWN keys. Once the change is made, press the MODE key once more for the new value to be entered into memory and to select the next parameter for setting.

The modification mode will be interrupted automatically after 3 seconds without activity on the keyboard.

The parameters that may be selected and displayed are the following:

- Hose temperature in automatic control mode (maximum 80° C / 176° F)
- Hose heating power (maximum 50 Amps)
- Isocyanate heater temperature (maximum 90°C / 194° F)
- Polyol heater temperature (maximum 90°C / 194° F)
- Total number of cycles to be made
- Number of cycles made



**Service Manual**

**1. Main Power Switch**

Turns the electric supply to the control panel on and off. It must be turned ON for any operation to be performed with the unit. When turned ON, the green pilot at the top of the switch will come on.

**2. Hoses**

The hose heating control may be automatic (optional) when using the TCS probe for direct temperature control, or manual when not using the TCS probe. The control mode must be established with two DIP selectors in the printed circuit. Set the "HOSE TEMP" DIP to ON if the Isocyanate hose includes a TCS probe; or set the one DIP selector to OFF if the Isocyanate hose does not have a TCS probe or if this is not operative due to breakdown or for any other reason.



The automatic control mode will show the temperature of the Isocyanate hose (ISO) on the corresponding display. In manual control mode, only the selected amps will be shown. **Please be aware that after manipulating the DIP selector you should switch off the unit so the change. (in detected buy the board)**

**HOSE TEMP ON**  
with TCS probe in the ISO hose

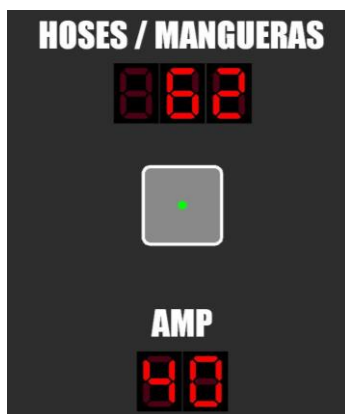

**HOSE TEMP OFF**  
manual control

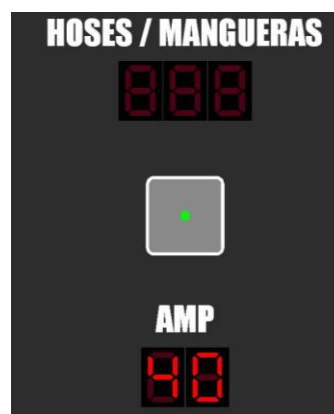

To select the temperature when the unit is working in automatic control mode, press the MODE key until the temperature flashes, select the required temperature by pressing the UP/DOWN keys and press the MODE key once more to enter the selected value into memory. Do the same process to select the Amps. When the unit is working in automatic mode, the value of the power must be set between 45 and 50 Amps.

Hose temperature settings that are higher than the temperature settings of the heaters cannot be programmed.

If only one temperature control system is working (ISO or POL), the limiting temperature value will be the highest set in the heaters.

If both temperature control systems are working (ISO and POL), the limiting value will be related to each of their corresponding heaters.

Temperature settings are restricted to 80°C maximum for hoses and 90°C maximum for heaters.



To enter data, the order will be as follows:

- The temperatures in ISO and POL heaters are set.
- The temperatures in ISO and POL hoses are set.
- Finally, the settings of the rest of the data can be entered in the date range and cycle pre-selector.

If the control probe is not operative, the temperature display will show the symbol (---) and the heating will be turned off.

The lower pushbutton activates turn on or off the heating of the hose of the product. The pushbutton has a led that lights when the heating is working; if the led flashes, it indicates that the heating is activated but fails to heat.

If excessive pressure is caused in the circuit of any of the products, the heating will stop working momentarily until the problem disappears.

AT start-up, the hose heat set point is not maintained in memory and must be reset after each activation of the CONTROL POWER key.

To select the hose power when the unit is working in manual heating control mode, press the MODE key until the amperage flashes, press the UP / DOWN keys to enter the number of amps required and press the MODE key once more to enter the value into memory.

Refer to the table shown below to select the power that is required to reach the application temperature:

30 A	38° C	100° F
35 A	48° C	118° F
40 A	60° C	140° F
45 A	75° C	167° F
50 A	80° C	176° F

Select the required amps for a quick pre-heating.

**NOTE:**

*The circuit breaker software of the transformer has a safety system to prevent the hoses from being exposed to high temperatures during long periods of time.*

*If you have selected a potential over 35 amperes, after 20 minutes, the potential will automatically regulate to 35 amperes.*

*This potential cannot be set above 35 amperes until the heater is disconnected from the hoses and reconnected.*

*The settings programmed by the machine operator will be stored for the next time the heating is switched on.*



## Service Manual

### 3. Heaters

The display shows the temperature in the Isocyanate heater (ISO) and the temperature in the Polyol heater (RESIN). To enter new temperature values, press the MODE key until the respective temperature flashes; select the required temperature by pressing the UP/DOWN keys and press the MODE key to enter the value into memory.

The pushbuttons turn on or off the heater of each product. Each pushbutton has a led that lights steady when the heater is on; if the led flashes, it indicates that the heater is at the preset temperature.

If excessive pressure is caused in the circuit of either product, the heating will stop working momentarily until the excessive pressure disappears.

If the temperature control probe stops working, the temperature display will show the symbol (---) and the heater will automatically be turned off.

At start-up, the heater set point is not maintained in memory and must be reset after each activation of the CONTROL POWER key.

### 4. Mode Key

Allows access to change the different control parameters.

### 5. UP / Down Keys

Allows the value of each of the parameters to be increased or decreased.

### 6. Counter

Indicator displays the cycles used and the cycles remaining from the preset. The cycle counter is incremental and may be reset by simultaneously pressing the UP / DOWN keys.

The system allows pre-selecting the required number of working cycles so that the unit will automatically stop when it reaches this number. To enter the number of cycles to reach automatic shutdown, press the MODE key until the cycle meter flashes, select the number of cycles with the UP / DOWN keys and press the MODE key to enter the value into memory.

When the unit starts, the cycles used will be deducted from the pre-selected cycles until the total number of cycles requested is completed. Once completed, the display will show zero and the unit will automatically stop.

The cycle meter display will alternate every two or three seconds to show the cycles used (totalizer) and the cycles remaining (pre-set). The cycles remaining will be shown by the Minus sign (-XXXXX). The counter display will also show any alarm warnings resulting from faults.

### 7. Power Control Key

Pushbutton turns on and off the control voltage to the electrical circuit of the heaters and hoses. When the key is on, the led in its center will come on. It may be turned off at will by pressing the key once more, or automatically if an alarm is caused due to excessive temperature in the heaters (alarms 6 and 7) or due to excessive current in the heating system of the hoses (alarm 9).

### 8. Motor Key

Pushbutton turns on and off the hydraulic motor. When the key is active, the led in its center will come on. This may be turned off at will by pressing the key once more, or automatically in the event of overload in the hydraulic motor (alarm 8). ***The function of the "Motor Key" selector is only active in the units with hydraulic actuation.***

### 9. Normal Key

Activates the normal operation of the machine. When the key is active, the led in its center will come on.



**10. Retract Key**

Sets the piston rod of the Isocyanate proportioning pump to the retract position and prevents the crystallization of Isocyanate on the piston rod. Press the RETRACT key every time the unit is stopped by the operator. When the key is active, the led in its center will come on.

**11. Direction Indicator Pilot Light**

Indicates the direction of movement of the proportioning pumps. If excessive pressure is caused in the system, the pilot lights will be turned off and alarms 3 and 4 will be active. The functions of the NORMAL and RETRACT keys will remain active.





## ALARMS

When the unit has faults caused by conditions affecting its correct operation, an audible alarm will sound and a fault number will show on the COUNTER display. The system does not allow an alarm to be reset until the fault causing the alarm has been corrected. After resetting, the MODE key must be pressed.

The procedures recommended to determine the possible causes activating the alarms are indicated in the following:

1. **Maneuvering Voltage under 170 V**
  - Check the electrical supply connections.
  - Check the transformer thermal limit switch.
2. **Maneuvering Voltage over 270 V**
  - Check the electrical supply connections.
3. **Excessive ISO Pressure (deactivates the directional valve and the heating system)**
  - Check the product pressure.
  - Check the number 10 led of the printed circuit: it must be lit.
  - Check the over pressure safety switch.
4. **Excessive POL Pressure (deactivates the directional valve and the heating system)**
  - Check the product pressure.
  - Check the number 11 led of the printed circuit: it must be lit.
  - Check the over pressure safety switch.
5. **Excessive ISO temperature (deactivates the POWER CONTROL)**
  - Check the heater heating system.
  - Check the connections of the safety thermostat and allow it to cool so that it makes an automatic reset.
  - Check the number 12 led of the printed circuit: it must be lit.
6. **Excessive POL temperature (deactivates the POWER CONTROL)**
  - Check the heater heating system.
  - Check the connections of the safety thermostat and allow it to cool so that it makes an automatic reset.
  - Check the number 13 led of the printed circuit: it must be lit.
7. **Fault key (it only turns on when the machine is connected to the main power supply)**
  - Check the keyboard.
8. **Fault in Hose Heating System (deactivates the POWER CONTROL)**
  - Replace the faulty triac.
9. **000000 Cycle Pre-selection made (deactivates the directional valve)**
  - Press the MODE key to reset the counter
  - Set the cycle selector to zero.



***Disconnect the unit from the main power supply before working on the inside of the electrical console. The electrical maintenance of the machine must only be performed by a qualified electrician.***

## METHOD OF THREADED UNION OF THE HOSES

Follow the torques for threaded joints listed in **Table 1** according to thread sizes of hose fittings to ensure their proper assembly.

There is also an alternative procedure to obtain an equivalent torque without using special tools: joint both ends of the hoses to be connected, tighten a swivel nut by hand (without using spanner) until there is resistance on the nut. Fit two spanners (1) on the fixed ends of the hoses and turn the swivel nut with a third spanner (2) as many flats from wrench resistance (FFWR) as indicated in **Table 1**.

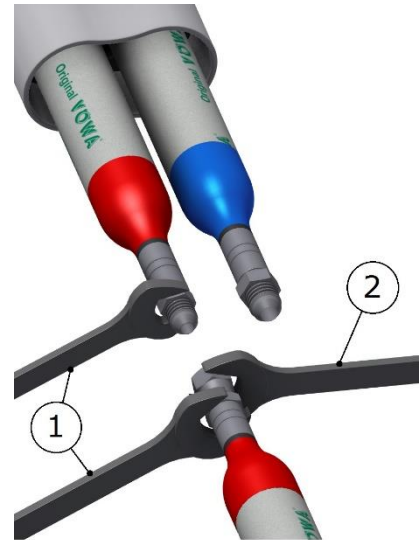

THREAD SIZE	TORQUE Nm	FFWR
1/2"-20	23	2 (or 120°)
9/16"-18	30	1-1/2 (or 90°)

**NOTE:** 1 FFWR corresponds to one complete shear of a flat marked with red between swivel and fitting or else 60°.

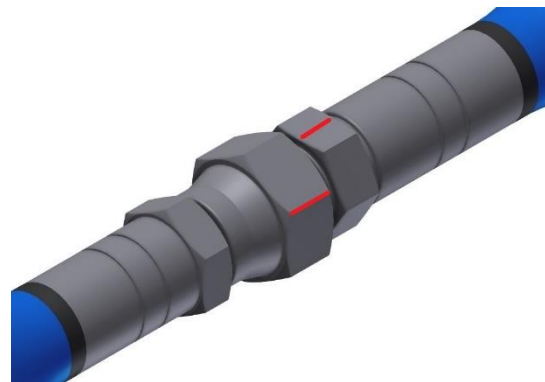
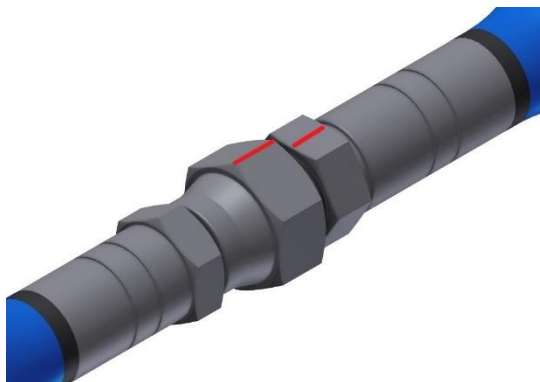



## INSTALLATION

**PRECAUTION!** Use suitable protection and follow the recommendations in the safety information provided by product suppliers when installing or working with the unit.

**HI-TECH** provides a series of tools and accessories necessary for assembling the machine. The kit is made up of the following elements:

BI-00009	Tube of lithium grease 50 gr	1x
HT-00001	Magnet holder tools	1x
NR-00007	Parts Identification Manual	1x
NR-00011	Service Manual	1x
NR-00045	Monobloc Pumps, Parts Manual	1x
MA-00102	12" Hoses Connection Cover	2x
EL-00093-01	White Flange 300 x 4.8	3x
HT-00045	Allen Key 1/8"	1x
EL-00100-06	Blue Terminal for Cable 16 mm <sup>2</sup> L=12mm	2x ①
TN-00242	Threaded Rod 1/4"-20 UNC x 14" nylon	2x ①
OPTIONALS		
EL-00051-00E	ISO TCS Assy with POL extension (For units with TCS)	1x ②
EL-00052-00E	ISO – POL TCS Assy (For units with TCS ISO+POL)	1x ③
MA-00102	12" Hose Connections Protector	2x ③
EL-00093-01	White Flange 300 x 4.8	3x ③
EM-00012	Hose TCS packaging	1x ②
EL-00100-06	Blue Terminal for Cable 16 mm <sup>2</sup> L=12mm	2x ②
		4x ③
TN-00242	Threaded Rod 1/4"-20 UNC x 14" nylon	2x ②
		4x ③
NR-00093	Recirculation kit Parts Manual	1x

① Units without TCS (standard version)

② Units with TCS on ISO hose (optional version)

③ Units with TCS on ISO + POL hoses (optional version)



**Inside the console, there is a terminal for connecting the principal electrical wire (not supplied) to the unit. The electrical connection of the unit must only be carried out by a qualified electrician.**

**NOTE:** To ensure that the unit works correctly, the electrical supply must meet the specifications indicated on page six of this manual and appearing on the machine specifications plate.

Follow the recommended procedure in the indicated order to install the unit:

- a) Insert the main power cable by passing it through the wire stop at the bottom of the electrical console and connect as shown in the diagram.

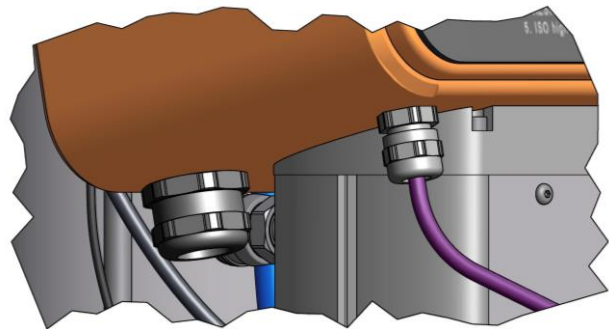

Use the proper size of cable according to the voltage, current and maximum power required by the Unit.

**The sizing of the cable is calculated for a length of 25m, for longer lengths you must recalculate the appropriate section.**

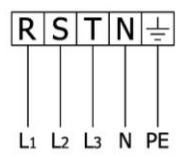
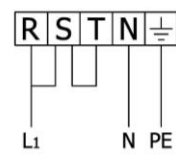
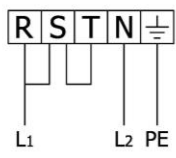
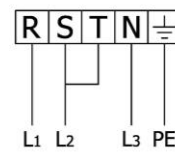
 3NPE~400V 50/60Hz		 1NPE~400V 50/60Hz		 2PE~230V 60Hz		 3PE~230V 50/60Hz	
<b>G-125 A</b>							
22,0 A @ 3NPE~400V		58,0 A @ 1NPE~400V		58,0 A @ 2PE~230V		43,5 A @ 3PE~230V	
Cable Section 6 mm <sup>2</sup>		Cable Section 10 mm <sup>2</sup>		Cable Section 10 mm <sup>2</sup>		Cable Section 6 mm <sup>2</sup>	
<b>G-200 A</b>							
26,0 A @ 3NPE~400V		67,0 A @ 1NPE~400V		67,0 A @ 2PE~230V		52,0 A @ 3PE~230V	
Cable Section 6 mm <sup>2</sup>		Cable Section 10 mm <sup>2</sup>		Cable Section 10 mm <sup>2</sup>		Cable Section 10 mm <sup>2</sup>	

Service Manual

**Make sure the power cable is disconnected from the main power supply before connecting it to the terminal in the console.**

- b) Fill the Isocyanate pump lubricating cup with DOTP plasticizer.
- c) Connect the hoses of the products to the outlets of the respective heaters (the Isocyanate hose to the Isocyanate heater and the Polyol hose to the Polyol heater).

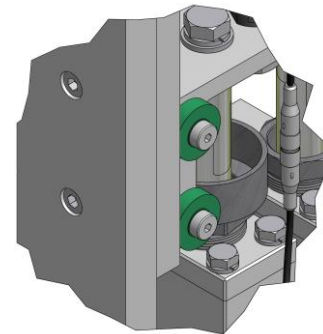

**NOTE:** The product hoses have been identified with red (Isocyanate) and blue (Polyol), enabling them to be rapidly distinguished. To avoid errors in connecting the coupling connectors of the Isocyanate and Polyol hoses, the connectors are of different sizes to make it impossible for connections to be swapped.

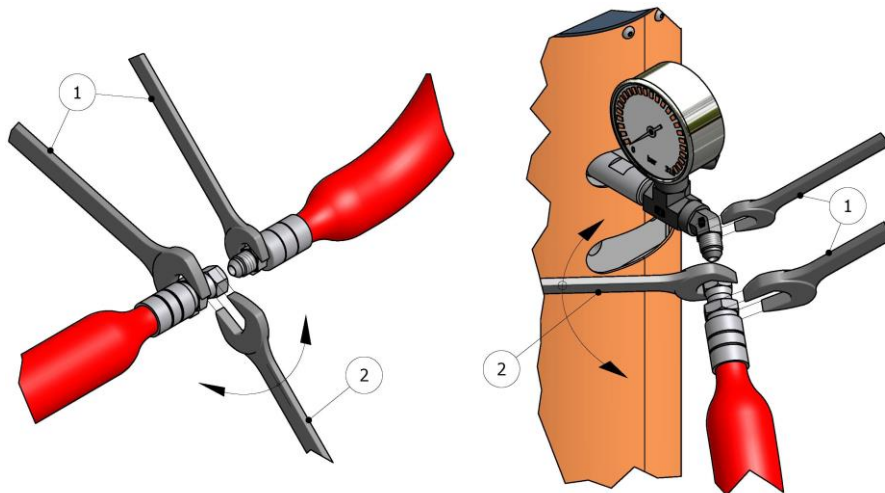

**Figure 3. Method of union of the Hoses**

**WARNING!** To join the hoses together or to connect them to the heaters or the gun, use two spanners to hold the parts to be joined (1) and a third spanner to tighten or loosen the connecting nut (2) as shown in the illustrations in Figure 3. The connections must be tightened to indicated in Table 1, pg.18.

The hoses receive vacuum drying treatment and are supplied interconnected at the ends to prevent them from absorbing moisture. Do not separate them until they are going to be installed in the unit.

The hose connection system includes special terminals (fast lock) to facilitate the electrical connection to the transformer and between the different sections installed in the unit.

The transformer offers the option of connecting to a 40 V output voltage valid for a total hose length of up to 48 meters (158 ft), or an output voltage of 75 V, for hose lengths of over 48 meters (158 ft). Connect to one output voltage or the other depending on the total hose length installed. Before starting up the unit, make sure that the connection

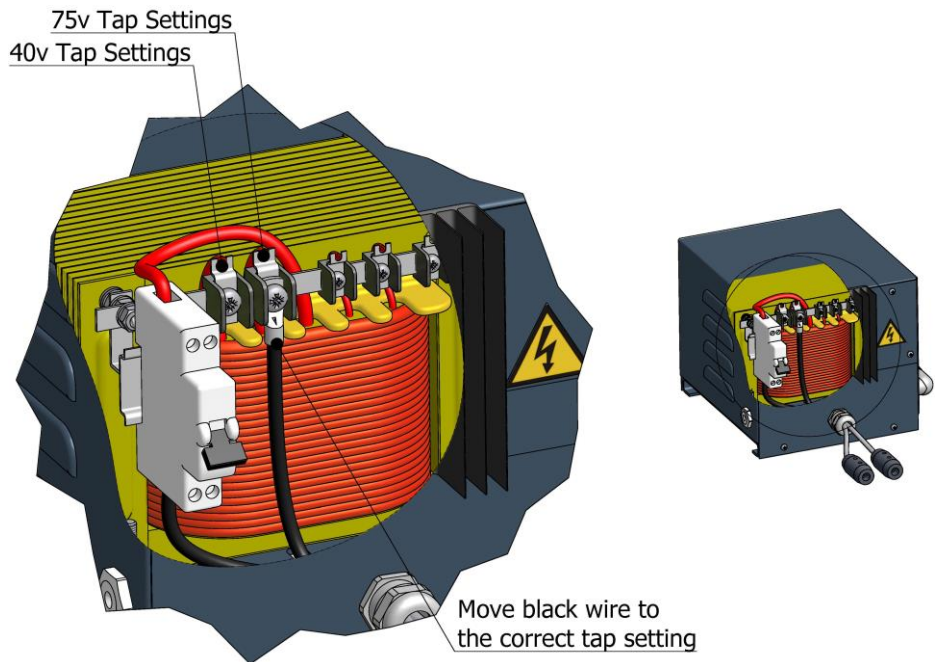

made in the factory matches the total length of hose installed. If you add or eliminate sections of hose, make sure the output voltage of the transformer to which it is connected is suitable for the resulting total length. Otherwise, change the connection.

- d) Connect the heated hoses wires to the “fast lock” connector coming out of the hose transformers as follow.:
  - a. Unscrew the Nylon Safety Plug from the “fast lock” connector body.
  - b. Unscrew partially the Socket Head Set Screw from electrical wires.
  - c. Insert the heated hose electrical wire with terminals into the “fast lock” connector body.
  - d. Tighten the Socket Head Set Screw of the terminals and place the Nylon Safety Plugs

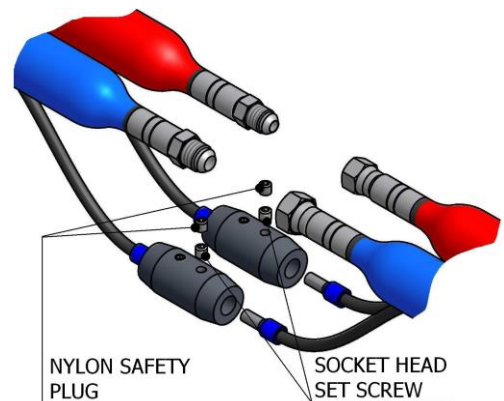

**NB:** A good practice is to add some dielectric grease to the ID of the connector.

Repeat the same steps to connect the “fast lock” that you will find in the middle hose connections

- e) Connect the rest of the product hoses to complete the required length. Remember that the hoses are identified with red (Isocyanate) and blue (Polyol).

Service Manual

**NB:** Assure the proper mechanical and electrical connection of the hoses to avoid possible product leakage and hose heat problems.

- f) Install the probe of control of temperature TCS between the last stretch of hose of product and the final stretch connected to the gun. Stretch carefully the cable of the probe inserting it in the Isocyanate hose.
- g) Attach the connector of the probes to the connector of the hose. Realize so many connections as stretches of 15 m hose you have.
- h) Realize the connections between the connector of exit of the probe TCS of the first stretch of hose and the connector proceeding from the machine.
- i) As soon as the connections were completed, place the protections for the union fixing them with three plastic bridles. Later cover the union with the ends of the cases.

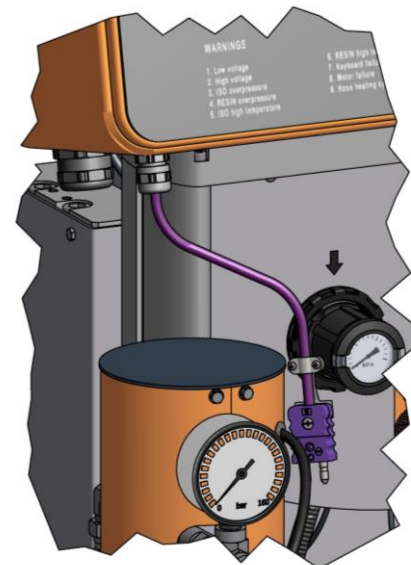
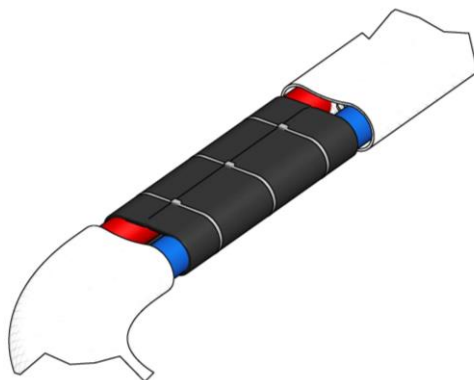
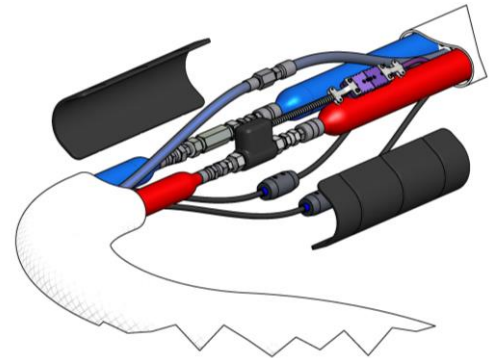

**NOTE:** Having fitted the TCS, you must pay special attention not to kink or excessively bend the hoses. Do not roll up the hoses with a radius of under one meter / 4ft.

- j) Connect the air hoses.
- k) Connect the hoses to the connectors of the coupling block of the gun, making sure that the manual valves are closed.
- l) Insert a contact thermometer through the hose insulation so that the bottom of the thermometer is in contact with the hoses and the top is outside the insulation. Fit the thermometer in such a way that the operators can see the temperature when they are spraying. If the hoses have STC probes to automatically control the temperature, the contact thermometer will not have to be installed.

Proceed to install the transfer pumps paying special attention to connect each pump to “its” product, as changing the pumps would cause a reaction in the products inside them and make them useless. Identify each pump with a tape of the same color as that of the hoses (blue for the Polyol pump and red for the Isocyanate pump) is a good method for avoiding errors in connection.

Do the following steps to install the pumps:

- a) Make sure that the inlet valves of the products to the unit are closed.



- b) Connect one end of the Polyol hose ( $\frac{3}{4}$ " thread) to the Polyol valve and the other end to the transfer pump of the same product.
- c) Connect one end of the Isocyanate hose ( $\frac{1}{2}$ " thread) to the Isocyanate valve and the other end to the transfer pump of the same product.
- d) Connect the air hose to the transfer pumps.
- e) Perform the unit ground connection. The speed of the product inside the hose can cause static electricity and produce electrical discharges.

Before using the unit, the retained air and the residual oil from the operating tests made in the factory must be eliminated. To purge the whole circuit, proceed as follows:

- a) Pressurize the transfer pumps and open the inlet ball valves. Make sure there are no leaks.
- b) Turn the pneumatic pressure regulator counter clockwise as far as it will go.
- c) Turn the general switch ON. The top pilot light will come on.
- d) Press the POWER CONTROL key.
- e) Keep the coupling block with the outlet of each product in separate vessels and open the manual valves of each product.
- f) Press the NORMAL key. The led will light
- g) If necessary, increase the pneumatic pressure by turning the regulator clockwise until the product pumps begin to slowly move.
- h) Allow the materials to come out of the coupling block until the residual oil and the air bubbling has disappeared completely.
- i) Close the manual valves of each product and clean the coupling block of the remaining supply of product.
- j) Slowly increase the pneumatic pressure to check for product leaks in the hose connections. Retighten if necessary and tape the connectors to protect them from possible damage.
- k) Press the RETRACT key.
- l) Mount the gun on the coupling block.





## START-UP PROCEDURES

Follow the recommended procedure in the indicated order.

**PRECAUTION!** *The start-up procedures assumes that all of the necessary adjustments have been correctly performed.*

- a) Check the state of the DOTP plasticizer in the Isocyanate pump lubrication cup. Change the oil if you see changes in the color or signs of solidification and retighten the packing nut to ensure the seal.
- b) Make sure that the chemical products to be processed are above the minimum temperature required to be supplied to the unit through the transfer pumps. Ask your product supplier for information on the minimum supply temperature.
- c) Check the inlet filters of the products. Clean them if necessary.
- d) Pressurize the two transfer pumps and open the inlet ball valves of the products to the unit.
- e) Turn the general switch ON. The top pilot light will come on.
- f) Press the POWER CONTROL key. The led will light.
- g) Press the key under the HOSES display. The led will light in the center of the key
- h) Press the ISO and RESIN keys under the HEATERS display when the products in the hoses reach the working temperature. The two leds will light.

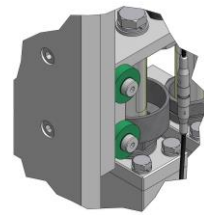

**PRECAUTION!** *To avoid excessive pressure in the heated hoses, wait for the product in them to reach the required temperature before starting up the air motor system.*

- i) Press the NORMAL key. The led will light. One of the direction indicator lights will come on and the proportioning pumps will begin to move.
- j) Using the air pressure regulators, first of all select the pressure for the down stroke of the proportioning pumps and then adjust the pressure for the up stroke. As a result of the difference in effective area between the lower face and the upper face of the plunger of the pneumatic cylinder, and due to the effect of the additional pressure supplied by the transfer pumps, there will be a small difference in pressure between the up and down stroke of the pumps. To balance the pressures, the value of the pneumatic pressure in the up stroke must be slightly lower (between 3 and 6 psi) than the value of the pneumatic pressure set for the down stroke of the pumps.  
The pressures must be practically the same and remain constant. The direction indicator lights must alternate with one on and the other out. The light that is on indicates the direction of movement of the pumps.  
If the pressures fluctuate on each stroke, consult the fault section before continuing.
- k) Connect the air supply to the gun; open the manual valves of each product; make a test projection and check the pressures on the product gages. If the projection test is correct and the pressures remain equal, proceed with the application



## SHUTDOWN PROCEDURES

Follow the recommended procedure in the indicated order for machine shut down when work is stopped for the day.

- a) Press the RETRACT key. The led will light.
- b) Use the gun to project into a waste container until the Isocyanate proportioning pump is in the retract position and the pressure begins to fall.

***PRECAUTION!*** To avoid possible seal weepage and the early failure of the pump seals, the pressure must not be reduced to zero. It is recommended to keep the system with a minimum pressure of 30 bar (400 psi) to extend the life of the seals.

- c) Press the ISO and RESIN keys under the heater temperature display. The two leds will go out.
- d) Press the key under the HOSES display. The led will go out.
- e) Press the POWER CONTROL key. The led will go out.
- f) Turn the general switch OFF. The top pilot light will go out.
- g) Close the inlet ball valves.
- h) Close the supply to the transfer pumps.
- i) Disconnect the air supply to the transfer pumps.
- j) Remove the contact thermometer and roll up the heated hoses.
- k) Close the manual valves on the coupling block and remove the gun to perform the corresponding maintenance.



## CLEANING

***PRECAUTION!*** *The unit includes components that reach temperatures that are liable to cause burns. The hot parts of the unit must not be handled until they have cooled.*

To avoid possible contamination, the circuits of the unit must be flushed clean (pumps, heaters and hoses) whenever applications have to be made that require a change of components.

Follow the recommended procedures in the order indicated to perform the cleaning:

- a) Place two drums of DOTP cleaning agent close to the machine.
- b) Dismantle the gun and leave the coupling block connected to the hoses.
- c) Remove the transfer pumps of the product drums and place them in the drums of the DOTP cleaning agent.
- d) Place 2 separate vessels under the coupling block to gather up the products contained inside the machine.
- e) Open the manual valves on the coupling block and press NORMAL key to start up the proportioning pumps.
- f) Allow the products to come out until you see that only DOTP cleaning agent comes out free of impurities.
- g) Close the valves on the coupling block and deactivate the NORMAL key.
- h) Place the transfer pumps in the drums of the new products.
- i) Place 2 separate vessels under the coupling block to collect the DOTP cleaning agent.
- j) Open the valves on the coupling block and press NORMAL key to start up the proportioning pumps.
- k) Allow the DOTP cleaning agent to come out until you see that only the new products come out.
- l) When the products come out without the contamination produced by the effect of the DOTP cleaning agent, the cleaning process is complete and you can proceed as normal.



## LONG TERM SHUTDOWN PROCEDURES

***PRECAUTION!*** *The unit includes components that reach temperature that are liable to cause burns. The hot parts of the unit must not be handled until they have cooled.*

When you plan to shut down the machine for more than FOUR weeks, the products contained in the machine must be replaced by DOTP plasticizing agent.

Follow the recommended procedures in the order indicated:

- a) Place two drums of DOTP cleaning agent close to the machine.
- b) Dismantle the gun and leave the coupling block connected to the hoses.
- c) Remove the transfer pumps of the product drums and place them in the drums of the DOTP cleaning agent.
- d) Place 2 separate vessels under the coupling block to gather up the products contained inside the machine.
- e) Open the manual valves on the coupling block and press the NORMAL key to start up the proportioning pumps.
- f) Allow the products to come out until you see that only DOTP cleaning agent comes out free of impurities.
- g) Deactivate the NORMAL key, close the valves on the coupling block, turn the general switch OFF, disconnect the supply system of the transfer pumps and the process is finished. The proportioning pumps, the heaters and the hoses must be full of DOTP plasticizing oil. ***Never leave the machine or the hoses empty of product or DOTP plasticizing oil.***

***NOTE:*** *Never use liquids not recommended or not approved by HI-TECH. Never use approved liquids that have been contaminated with water or ISO/POL. If you are not sure in the quality of the liquid you are going to use we strongly recommend that you check the machine 2-3 times every 2 weeks after you have filled it by recirculating through heated hoses (see p.27) with fresh plasticizer unless you make sure the liquid that comes out is completely pure and clean.*



## TROUBLESHOOTING

The **evolution G-125 A / G-200 H** unit has been designed and built to withstand severe working conditions with a high degree of reliability, provided it is used suitably. This chapter contains information on possible faults that may prevent the continuation of work with the unit. The information provided must serve as guideline to detect and resolve the large majority of the problems before calling for the assistance of the authorized distributor or **HI-TECH** technical service. In any case, feel free to contact the technical assistance service of **HI-TECH SPRAY EQUIPMENT, S.A.** where a qualified technician will advise you on whatever you may need.

**All repairs performed by unqualified personnel or the use of spares other than originals may cause damage to the unit and put the operator at risk.**



**To prevent possible bodily harm caused by incorrect handling of the raw materials and solvents used in the process, carefully read the safety information provided by your supplier.**

**Deal with the waste caused according to current regulations.**



**Disconnect the unit from the power supply before carrying out any operation inside the electrical console.**

**The electrical maintenance of the machine must only be performed by a qualified electrician.**



**To avoid damage caused by the impact of pressurized fluids, do not open any connection or perform maintenance work on components subject to pressure until the pressures have been completely eliminated.**

**Use suitable protection when operating, maintaining or remaining in the operating area of the unit. This includes, but is not limited to, the use of face masks, protective goggles, gloves, shoes and safety clothing.**



**The unit includes components that reach temperature that are liable to cause burns. The hot parts of the unit must not be handled until they have cooled.**



**To prevent serious harm by crushing or loss of limbs, do not work with the unit without the safety duly installed on all moving parts. Make sure that all of the safety protections are correctly fitted after all repair or maintenance work.**

## Heaters

**WARNING!** Before resolving any kind of defect, make sure all of the pushbuttons are off, that the general switch is in shutdown position and that the unit is disconnected from the power supply. Never handle the inside of the control panel with the unit connected to the main power supply. The heaters are components that reach high temperatures; wait until they have cooled before handling.

**NOTE:** The thermostat is a safety element in contact with the heater. If the temperature exceeds 120° C (248° F) the thermostat will cut off the electric supply by deactivating the POWER CONTROL. The thermostat will not reset until the temperature in the heater is below 120° C (248° F).

If the temperature in the Isocyanate heater or the Polyol heater is over 120° C (248° F), an alarm will be activated and the corresponding number will be shown on the control panel (5 for Isocyanate and 6 for Polyol).

Follow the recommended procedure in the order indicated, to try to solve the problem and avoid costly repairs. Make sure all the automatic switches and control elements are in the correct working position before determining the existence of a fault.

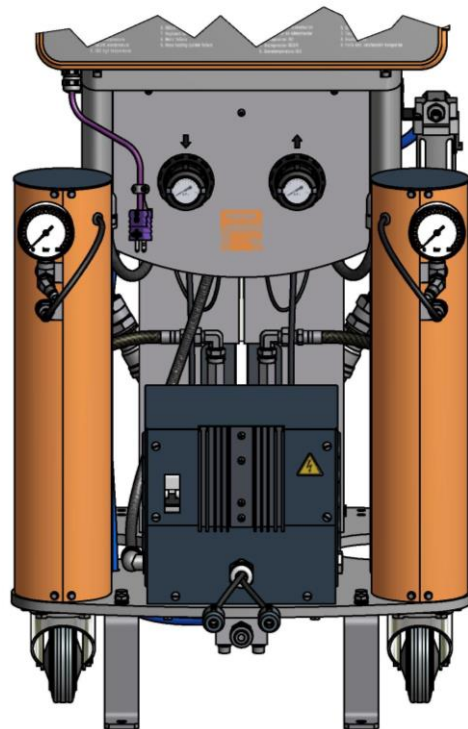

### PROBLEMS

The heater fails to heat, the pushbutton led is lit.

The heater display shows the symbol (---)

### SOLUTIONS

1-2-3

4

### SOLUTIONS

#### 1. Static Relay

This determines that the static relay is not working when all of the previous checks have been correct.



**Service Manual**

**2. Heating Elements**

Each heater includes four 1250 W (1500 W G-200 A) elements connected in parallel, which give the system a total power of 5000 W (6000 W G-200 A). If under normal conditions of room temperature it is not possible to reach the required temperature in two or three minutes, it is possible that several heating elements are not working.

To check the state of the elements, proceed as follows:

With the main switch off check with a tester that reading the total value of the heater resistance is indicated in the table according to the power, voltage and number for each installed heater elements, a higher value would indicate that one or more elements are faulty .

Disconnect them and check that the individual value of each element is as shown in the table according to the installed power and voltage.

**Table 2. Elements Values List**

(W)	(V)	x1 (Ω)	x2 (Ω)	x4 (Ω)	x6 (Ω)
450	230	117±2	58±2	29±2	19±2
900	230	58±2	29±2	14±2	9±2
900	400	177±2	88±2	44±2	29±2
1250	230	42±2	21±2	10±2	7±2
1250	400	128±2	64±2	32±2	21±2
1250	440	154±2	77±2	38±2	25±2
1500	230	35±2	17±2	8±2	5±2
1500	400	106±2	53±2	26±2	17±2
1500	440	129±2	64±2	32±2	21±2
1800	230	29±2	14±2	7±2	4±2
1800	400	88±2	44±2	22±2	14±2
1800	440	107±2	53±2	26±2	17±2
2000	230	26±2	13±2	6±2	4±2
2000	400	80±2	40±2	20±2	13±2
2000	440	96±2	48±2	24±2	16±2

Under extreme environmental conditions, the heater might be affected and fail to reach the required temperature. In this case, put the unit in a more favourable place, or use an auxiliary heating system.



### **3. Automatic Switch**

This protects the elements against any possible change in voltage. With the general switch turned off, open the control panel and make sure the switch is activated (see electrical diagram), otherwise activate it.

### **4. Temperature**

The control panel automatically detects any fault in the operation of the temperature. If the fault occurs, replace the probe, paying special attention not to damage it when assembling. The probe must be in firm physical contact with the element.





## Hose Heating

**WARNING!** Before resolving any kind of defect, make sure all of the pushbuttons are off, that the general switch is in shutdown position and that the unit is disconnected from the power supply source. Never handle the inside of the control panel with the unit connected to the power supply. The hoses can reach high temperatures; wait until they have cooled before handling.

If a fault occurs in the heating system of the hoses, an alarm will be activated and the number 9 will be shown on the control panel.

Follow the recommended procedure in the order indicated, to try to solve the problem and avoid costly repairs. Make sure all the automatic switches and control elements are in the correct working position before determining the existence of a fault.

### PROBLEMS

### SOLUTIONS

The hose is hot, but fails to reach the selected temperature.	1-2-7
The hose is not hot; the pushbutton led is lit.	2-3-4-5
Only the sections of the hose closest to the unit are heated.	5
The hose display shows the symbol (---).	6
The automatic switch is triggered.	3

### SOLUTIONS

#### 1. Hose Length

The **evolution G-125 A** has been designed to work with a maximum hose length of 93 metres /310 ft. A longer length will render the heating capacity less effective. Under extreme environmental conditions, the hose heating system may be affected and fail to reach the required temperature.

#### 2. Hose Transformer

The transformer offers the option of connecting to a 40 V output voltage valid for the connection of hose sections with a total length of up to 45 metres / 160 t, or an output voltage of 70 V, for connecting hose lengths of over 45 metres / 310 ft; connect to one or the other position depending on the total hose length installed in the machine. If the connection is performed incorrectly, the hoses will not reach the required temperature.

#### 3. Automatic Switch

This protects the secondary circuit of the transformer. The switch is located on the front of the transformer; make sure it is turned on, otherwise turn it on. Replace it with one of an equal amperage if the switch fails to work correctly.

**PRECAUTION!** The replacement of the automatic switch with another of different characteristics may cause damage to the equipment and put the operator at risk.



#### 4. Triac

This determines that the triac is faulty when all of the previous checks have been correct. Replace the triac if it fails to work correctly.

#### 5. Hose Heating Components

With the general switch turned off, make sure the hose connectors and the electrical connections between the hoses and the unit are correct and well fixed. If the connections are correct and the hoses do not heat up, check section by section to locate the connection that is failing.

Proceed as in the following:

- a) Disconnect the unit from the power supply by deactivating the general switch and start to check the hose section closest to the gun. Remove the "Fast Lock" connector, and make a "bridge" on the connection immediately before.
- b) Restore the power supply, press the POWER CONTROL key and the key under the HOSES display. If the heating works, the problem will be in the last section of hose. Replace it. If not, do the following.
- c) Disconnect the unit from the power supply, remove the "Fast Lock" connector from the last section of hose and make a "bridge" on the connection immediately before.
- d) Restore the power supply, press the POWER CONTROL key and the key under the HOSES display. If the heating works, the problem will be in the last but one section of hose. Replace it. If not, repeat steps c) and d) until you find the point of the fault.

#### 6. TCS Temperature Control Sensor

The control panel automatically detects any fault in the operation of the temperature sensor. To determine if the mistake is caused by the proper probe or by a defective electrical connection, realize the following cross-check: dismantling the electrical connector of the probe TCS of the last stretch of hose and without dismantling any other connection connect it straight to the electrical capture of the exit of the machine, if the control is restored check the electrical connections of the probe existing TCS in the intermediate stretches of the hoses, in the opposite case replace the probe TCS.

#### 7. Hose Heating Temperature Adjustment

The hose heating system has the function of maintaining the temperature of the products proceeding from the heaters, which is why the value set for the temperature of the hoses must be the same as that selected on the heater display.



## Proportioning Pumps

**WARNING!** Before resolving any kind of defect, make sure all of the pushbuttons are off, that the general switch is in shutdown position and that the unit is disconnected from the power supply source. Never handle the inside of the control panel with the unit connected to the power supply. The proportioning pumps are components that work under pressure; do not open any connection or perform repair or maintenance work on component subject to pressure until all of the pressures have been completely eliminated.

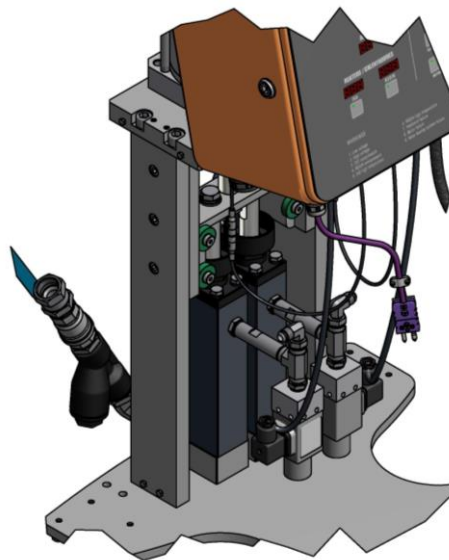

If excessive pressure is caused in the Isocyanate circuit or the Polyol circuit, an alarm will be activated that will be shown on the control panel (3 for the Isocyanate and 4 for the Polyol).

Follow the recommended procedure in the order indicated, to try to solve the problem and avoid costly repairs. Make sure all the automatic switches and control elements are in the correct working position before determining the existence of a fault.

### PROBLEMS

### SOLUTIONS

The pumps fail to maintain the pressure when the unit is shut down.	1
There are pressure differences between the proportioning pumps.	1-2-3
There is cavitation in the proportioning pump.	1-2-3
The proportioning pumps do not change direction.	4-6
The proportioning pumps fail to move and the direction indicator lights are out.	4-5
The movement of the proportioning pumps is erratic.	4-6
Difference in pressure or speed in the rising movement with respect to the falling.	7



## SOLUTIONS

### 1. Loss in the Ball Checks

Observe the manometers to identify which pump fails to maintain the pressure and check that the direction indicator light is lit to determine in which direction the pump fails to maintain the pressure. If the light on the left is on, check the ball in the aspiration valve (lower valve) of the isocyanate or polyol pump - depending on which pump is losing pressure. If the right light is on, check the ball in the discharge valve (upper valve) of the isocyanate or polyol pump depending on which pump is losing pressure.

Proceed as follows to check the ball checks:

- a) Disconnect the machine from the power supply and close all supply valves and the supply system to the transfer pumps.
- b) Depressurise the proportioning pump and remove the corresponding ball check.
- c) The loss from the ball checks is usually caused by foreign particles that prevent the perfect coupling of the ball in the housing at the top of the closing bushing. Clean the ball and the seat of the bushing and make sure there are no faults from nicks, marks or scratches to the bushing or the ball. If cleaning fails to resolve the problem or any fault is observed, replace the bushing and the ball.

### 2. Unbalanced Pressures

Pressures are unbalanced when there is an obstruction in the hose or in the gun that prevents one of the components from leaving freely through the gun chamber when it is projected, or when a problem in the pumping system prevents one of the components reaching the gun in the required amount.

To identify which component is relatively easy if we bear in mind that the chemical components used in the polyurethane foaming are of a different color. By observing the color of the material that leaves the gun, we can determine which component is missing.

To determine whether the unbalance is caused as a result of an obstruction or as a consequence of a problem in the pumping system, project with the gun, observe the pressure indicated on the corresponding pressure gage to the missing component and compare it with the pressure indicated by the gage to the other component: if the pressure of the missing component is higher, the unbalance is the result of an obstruction, if the pressure is lower, the unbalance is the consequence of a problem in the pumping system.

### 3. Cavitation

Cavitation occurs when the proportioning pump requires a larger volume of material than that supplied by the feeding system, causing the formation of a vacuum in the proportioning pump. The causes of cavitation are the following:

- a) The transfer pump fails to supply the necessary volume. The problem might be in the pump not meeting the required specifications, in the lack of air supply to the pump or that the pump is faulty. A pump is recommended with a ratio of 2:1 for transferring the Isocyanate and a supply hose with an interior diameter of at least 20 mm.
- b) High viscosity: the polyurethane foaming systems normally require a minimum transfer temperature of 12° C; at lower temperatures, the product increases in viscosity, making the pumping more difficult. When the ambient conditions prevent the products from being maintained at a minimum temperature of 12° C auxiliary heating elements must be used to condition the products as the minimum temperature required for the transfer.



## Service Manual

- c) The product inlet filter is obstructed (see Maintenance).
- d) The inlet ball valve has leaks as a result of wear or possible faults in the ball or the closing surface of the bushing, which means that part of the material supplied returns to the supply tank and that the proportioning pump supplies a smaller volume of material in the discharge cycle, causing an incorrect ratio.

### 4. Fault in the Direction Change Micro

The pneumatic cylinder that drives the supply pumps has two magnetic position detectors for making the change of direction. Each detector includes an led to indicate when it is active. Any accidental movement of the detection position will prevent the pumps from making the change in direction, which will oblige the detector to be put back into the correct position by using the gauge supplied with all of the accessories.

### 5. Safety Pressure Gauges

The proportioning pumps are protected by safety pressure gauges adjusted in factory to a pressure of 125 bar / 1800 psi on the evolution G-125 A Model and 210 bar / 2980 psi on the evolution G-200 A. When the limit pressure is exceeded, the pressure gauge cuts the electrical supply to the directional valve, thus stopping the pumps. When the pumps stop, the direction indicator lights will go out and an alarm will be activated that will be shown on the control panel (3 if the excess pressure is caused in the Isocyanate circuit or 4 if it is caused in the Polyol circuit).

When the pressure reaches lower values than the established limit, the proportioning pumps will start. To avoid the incident from reoccurring, the causes of the surplus pressure must be determined and corrected.

### 6. Guiding Rollers

The guiding rollers may sometimes be blocked due to dirt caused by remain power supply of crystallized Isocyanate. Change the rollers if they fail to turn freely.

### 7. Rising Movement Pressure Regulator

During the up stroke, the proportioning pumps receive additional pressure through the effect of the supply of products through the transfer pumps. Adjust the up stroke regulator so that the pressure of the proportioning pumps is the same in both directions.

## MAINTENANCE

To achieve maximum output from the **evolution G-125 A / G-200 A** unit, certain daily or regular maintenance operations are needed.



***To prevent all possible body harm caused by incorrect handling of the raw materials and solvents used in the process, carefully read the safety information provided by your supplier.***

***Deal with the waste caused according to current regulations.***



***Disconnect the unit from the power supply before carrying out any operation inside the electrical console.***

***The electrical maintenance of the machine must only be performed by a qualified electrician.***



***To avoid damage caused by the impact of pressurized fluids, do not open any connection or perform maintenance work on components subject to pressure until the pressures have been completely eliminated.***

***Use suitable protection when operating, maintaining or remaining in the operating area of the unit. This includes, but is not limited to, the use of masks, protective goggles, gloves, shoes and safety clothing.***



***The unit includes components that reach temperature that are liable to cause burns. The hot parts of the unit must not be handled until they have cooled.***



***To prevent serious harm by crushing or loss of limbs, do not work with the unit without the safety duly installed on all moving parts. Make sure that all of the safety protections are correctly fitted after all repair or maintenance work.***



## Heaters

**WARNING!** Before performing any maintenance work, make sure all of the pushbuttons are off, that the general switch is in shutdown position and that the unit is disconnected from the main power supply source. Never handle the inside of the control panel with the unit connected to the power supply. The heater is a component that reaches high temperatures; wait until it has cooled before handling.

### 1. Heating Elements

To replace a faulty element, proceed as followings:

- a) Depressurize the unit, disconnect it from the power supply and remove the cover on the heater.
- b) Disconnect the element from the terminal block with an appropriate spanner, loosen the element and remove it from its housing. Inspect the element; it must be smooth and shiny in appearance. If it is blackened or has material adhered to it, replace the element.
- c) Check the new element with a tester: the reading of the value of the resistance must be as shown in **Table 2** on **pag.31**.
- d) Apply Teflon or sealing paste to the thread and screw the element into its housing.
- e) Reconnect the wires to the connection block; make sure the connection is in parallel and fit the heater cover.

**NOTE:** If the element that has to be replaced is the one in contact with the temperature probe, first remove the probe.

### 2. Temperature Probe

The temperature probe is fixed to the connector with a ferule and a torque nut. Once inserted in its housing, the ferule forms part of the probe and does not allow it to be relocated or moved. The location of the probe is very important and must be done correctly before fitting the torque nut.

- a) Depressurize the unit and disconnect it from the power supply. Check the torque of the body of the connector inserted in the heater to prevent leaks.
- b) Install the heating element.
- c) Insert the torque nut and the ferule in the probe and insert this in the connector body until it comes into positive contact with the heating element. Make sure the spring does not prevent the probe from making contact with the element.
- d) Fix the probe in place and fit the torque nut.



## Proportioning Pumps

**WARNING!** Before proceeding with maintenance works, make sure that all push buttons are switched off, the general switch is in the off position, and the Unit is unplugged from the power supply. Never handle the control panel interior while the Unit is plugged into the electricity grid. Dosing pumps are components that work under pressure, do not open any connections or perform any repair or maintenance work on components submitted to pressure until all pressures have been completely released.

When the pump works properly, it is not uncommon for a small amount of resin to filter through the joints and reach the visible part of the pump axis. Periodically inspect the axis and clean the residue when dosing pumps are stationary and the machine is switched off.

Disassemble and clean the dosing pumps annually, despite no obvious signs of leaks. Use this time to completely replace the joints and bearings given that, if you reassemble an element that does not seem damaged, it can cause premature wear in the remaining components (the NR-00045 Components Manual includes the joint kits that correspond to each pump model and size). Pump distribution bases must also be inspected, checking that the ball valves show no signs of wear, dents or marks that affect the pump's proper operation.

Perform a daily inspection of the Isocyanate pump lubrication bowl and check the condition of the DOTP plasticiser oil it contains. Replace the oil when you observe colour changes or when it shows signs of solidification. If this circumstance persists, replace the isocyanate pump joints using the corresponding kit.

In cases where the machine is submitted to large workloads or special work conditions, disassemble, clean and replace the dosing pump joints every six months.

Inspect rods, pistons and inside the sleeves for marks or scratches that may cause leaks or premature damage to the joints.

Only qualified personnel will be authorised to replace dosing pump joints, since they have the required expertise to that effect.

To assemble the pump, there are specific tools that prevent damage to the seal lips of both the piston and the cylinder head.



Service Manual

First, assemble the rod set with the piston and all its components. Ensure that the piston seal lips are facing upwards.

Insert the assembled piston set inside the sleeve with the specific tool (1) (see **Table 3** on page 42).



Once you have inserted the piston into the sleeve, you must assemble the cylinder head seal. First place the seal funnel tool (2).

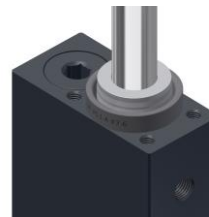

Next, place the cylinder head seal with the lips facing downwards.



Subsequently, you must place and fasten the tool (3) to the sleeve and insert the plunger (4) inside the rod. Screw as far as it will go.

Remove all the tools and finish the pump assembly by placing the guide with its joint, and fastening the piston and the nut with the bowl.

**Table 3. List of Tools**

	Tool (1)	Tool (2)	Tool (3)	Tool (4)
Size				
#4,5	HT-00034	HT-00116	HT-00119	HT-00121
#7,6	HT-00031	HT-00117	HT-00120	HT-00122

**Note:** These tools are not supplied with the machine, they are optional upon request.



## *Inlet supply filters*

The filter bodies have a filter screen that prevents solid particles from entering the unit. Inspect the filters each day as part of the machine start-up, and clean them. Replace the filter screen if necessary.

Isocyanate is a product that crystallizes with ambient moisture or freezing. If the storage and transfer is correct and the operating procedures are respected, the risk of contamination of the Isocyanate filter will be minimized.

***NOTE: Clean the Isocyanate inlet filter before the daily start-up; it should not be cleaned after the machine has been stopped for the day. Immediately beginning to project after cleaning the filter reduces the risk of absorption of moisture and the possibility of contamination through the reaction with the solvent used in the cleaning operation.***

To check the product inlet filters, proceed as follows:

- a) Disconnect the unit from the power supply and close the inlet ball valve from the filter you wish to check.
- b) Place a suitable vessel under the filter to collect the product coming out on removal. Carefully loosen the filter stopper to allow the product to be emptied into the vessel below. Completely unscrew the stopper.
- c) Remove the seal, the spring and the mesh and clean it all with the solvent used for cleaning the gun. Dry it all and check that the mesh is not obstructed. The holes in the mesh must be completely free. Replace the mesh if more than 10% of the surface is obstructed.
- d) Refit the mesh, the spring and the seal. Screw on the stopper.
- e) Open the product entry valve of the filter, make sure there are no leaks and proceed with the normal operation.



## *Isocyanate pump lubrication system*

Each day, inspect the lubrication cup of the Isocyanate pump and check the state of the DOTP plasticizing oil. Replace the oil when it shows changes in color or signs of solidification.

The DOTP oil solidifies as a result of the absorption of moisture and the maintenance interval will depend on the working conditions.

The oil discoloration is due to the small film of Isocyanate that lies on the pump shaft during the pumping operation. If the gaskets and the seals are in a good state, the plasticizing oil will not have to be changed so frequently.

To replace the plasticizing oil of the pump, proceed as follows:

- a) Use the gun to project until the Isocyanate proportioning pump is at the highest point of the rising run. Press the NORMAL key to interrupt the working cycle. The pushbutton led will go out.
- b) Press the POWER CONTROL key and turn the general switch to OFF. Disconnect the machine from the power supply.
- c) Remove the existing DOTP oil from the cup, clean the cup and the shaft of the pump, eliminating any remain power supply of polluted oil or crystallized material. Use a wooden or plastic tool to clean the shaft. Fill the cup with new DOTP plasticizing oil.



## CONTENT

<b>Warranty</b>	<b>2</b>
<b>Safety and Handling</b>	<b>3</b>
<b>Characteristics</b>	<b>6</b>
Principal Heating System	6
Proportioning System	6
Hose Heating System	7
<b>Technical Specifications evolution G-125 A</b>	<b>8</b>
Electrical	8
Mechanical	8
Acoustic	8
<b>Technical Specifications evolution G-200 A</b>	<b>9</b>
Electrical	9
Mechanical	9
Acoustic	9
<b>General Description</b>	<b>10</b>
<b>Control panel</b>	<b>12</b>
<b>Alarms</b>	<b>17</b>
<b>Method of Threaded Union of the Hoses</b>	<b>18</b>
<b>Installation</b>	<b>19</b>
<b>Start-up procedures</b>	<b>25</b>
<b>Shutdown procedures</b>	<b>26</b>
<b>Cleaning</b>	<b>27</b>
<b>long term shutdown procedures</b>	<b>28</b>
<b>Troubleshooting</b>	<b>29</b>
Heaters	30
Hose Heating	33
Proportioning Pumps	35
<b>Maintenance</b>	<b>38</b>
Heaters	39
Proportioning Pumps	40
Inlet supply filters	43
Isocyanate pump lubrication system	44
<b>Content</b>	<b>45</b>



List of Illustrations _____	46
List of Tables _____	46

## LIST OF ILLUSTRATIONS

Figure 1. General Description _____	10
Figure 2. Control Panel _____	12
Figure 3. Method of union of the Hoses _____	21

## LIST OF TABLES

Table 1. Tightening Threaded Joints _____	18
Table 2. Elements Values List _____	31
Table 3. List of Tools _____	42